

BATTERY PACK & CHARGER MANUAL



Battery and USB Charger NOT Included

MBC-24JST USB Charger

This charger is designed to charge the included 7.2V NiMH packs only. DO NOT charge any other type of battery. It is NOT intended for LiPo or Li-ion packs; or packs of a lower or higher voltage rating. When connected to a standard USB power source (500 mA or above is recommended), a red LED will light up indicating that the power is ON. During charging the maximum charging current is approx 100mA, and when the pack is fully charged, the charging current will drop. A typical time to fully charge a completed drained battery is 2 hours. After charging, disconnect the USB charger, and the pack. It is normal for the pack itself to feel slightly warm after charging.

NOTE: A partly discharged pack will take shorter time to be fully charged. BUT, due to the physiology of the NiMH packs, and their tenancy for memory effect, it is always best to fully discharge and cycle NiMH packs. It may take a few cycles for your pack to reach its full potential.

REMEMBER: younger RC fans must always charge the pack under adult supervision, and never leave the charging pack unattended. The red LED will NOT turn off, it only indicates that USB power is present. It is advised that you set a timer to independently notify you when the 2 hour charge cycle is complete. Failure to adhere to the correct charging procedure can lead to permanent damage to the pack, and in extreme cases, fire or personal injury. Charge smart, charge safe, follow guidelines.

SPARE PARTS

- | | |
|--|---|
| 15389 GT24B Hardware Set | 15451 GT24B Spur Gear 59T |
| 15390 GT24B Servo Saver and Mount | 15452 GT24B Front Bumper Set |
| 15392 GT24B Front Gear Box Housing | 15653 Micro Car Body Clip |
| 15393 GT24B Rear Gear Box Housing | 15752 GT24i20 Front Wheel and Tire Set Assembled (pair 2 pcs) |
| 15394 GT24B Differential Gear Set | 15753 GT24i20 Dog Bone (pair 2 pcs) |
| 15395 GT24B Center Drive Shaft Set | 15754 GT24i20 Shocks Assembled (pair 2 pcs) |
| 15396 GT24B Slipper set | 15755 GT24i20 Steering Linkage |
| 15401 GT24B Motor Mount Set | 15756 GT24i20 Front Suspension Arm Set |
| 15404 GT24B Outdrive set | 15757 GT24i20 Rear Suspension Arm Set |
| 15405 GT24B Front Shock Tower | 16125 GT24 ESC/RX Module N Version |
| 15406 GT24B Rear Shock Tower | 16126 GT24 Subaru Clear Car Body Set |
| 15410 GT24B Front Hub Set | 16130 GT24 Subaru Decal Sheet Set |
| 15411 GT24B Rear Hub Set | 16131 GT24 Subaru Wheel Set (4pcs) |
| 15413 GT24B Chassis and Cover Set | 16132 GT24 Subaru Tire Set (4pcs) |
| 15414 GT24B Body Post and Battery Cover | 16124 GT24 Subaru Painted Body Set |
| 15415 GT24B Bearing Set | |
| 15416 GT24B Plastic Screw Nut For Wheel | |
| 15429 8000KV Mini 130 Brushless Sensorless | |
| 15434 GT24B Replacement Servo | |



Visit us on www.carisma-shop.com

©2019 Carisma. All Rights Reserved. Product specifications are subject to change. Some models shown are prototypes which may vary slightly from what is inside.

Intellectual Property Right License by FUJI HEAVY INDUSTRIES LTD.



Printed in China
MAN-G00742

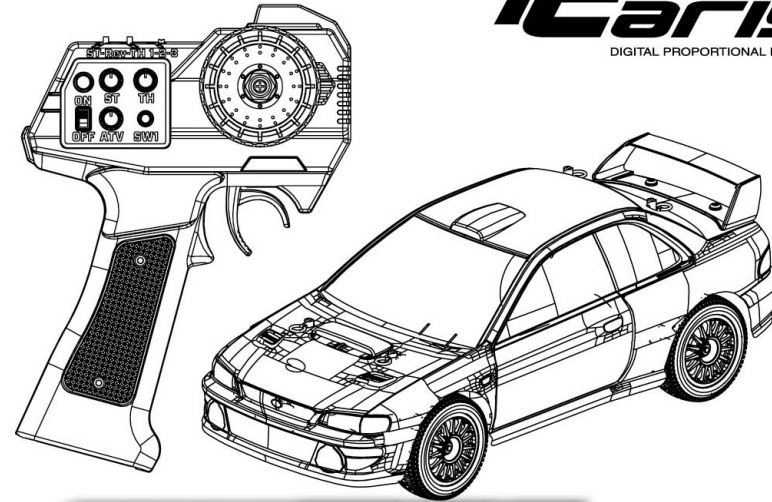

DIMENSION
SCALE: 1/24
HEIGHT: 64mm
TYRE: Ø36mm (width)
LENGTH: 180mm
WIDTH: 107mm
WHEELBASE: 119mm

GT24 INSTRUCTION MANUAL

POSSIBLY THE COOLEST MICRO RALLY ON THE PLANET

SUBARU IMPREZA WRC 2000



WHAT'S IN THE BOX

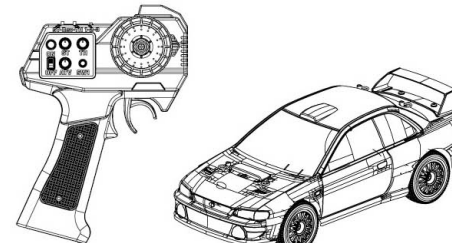

Transmitter

R/C Car



USB Charger



7.2V NiMH Battery Pack



4 x AA Batteries



Pinion Gear 14T



Pinion Gear 13T



Spur Gear 58T

TOOLS RECOMMENDED (NOT INCLUDED)

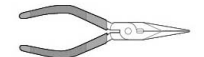

Long Nose Pliers

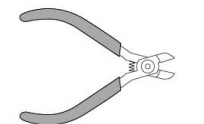

Nippers



Soft Brush

SAFETY PRECAUTIONS

SAFETY PRECAUTIONS

Beginner should seek advice from experienced person in order to assemble the model or parts correctly and to make best performance. * Assemble this model or parts only in place out of children's reach, and take safe precautions before operating this model. User is fully responsible for the model assembly and safe operations.

Introduction

This is a sophisticated hobby product and not a toy. It must be operated with caution and common sense. User also requires some basic mechanical abilities. Failure to operate this product in a safe and responsible manner could result in injury or damage to the product or other properties. This product is not intended for use by children without direct adult supervision. The product manual contains instructions for safe operation and maintenance. It is essential to read and follow all the instructions and warnings in the manual prior to assembly, setup or use, in order to operate correctly and avoid damage or injury.

Safety, Precautions, and Warnings

As the user of this product, you are solely responsible for operating it in a manner that does not endanger yourself and others or result in damage to the product or the property of others.

This model is controlled by a radio signal that is subject to interference from many sources outside your control. This interference can cause momentary loss of control so it is necessary to always keep a safe distance in all directions around your model, as this will help to avoid collisions or injury.

- Always operate your model in an open area away from cars, traffic, or people.
- Avoid operating your model on the street where injury or damage can occur.
- Never operate the model out into the street or populated areas for any reason.
- Never operate your model with low transmitter batteries.
- Carefully follow the directions and warnings for this product and any optional support equipments (chargers, rechargeable battery packs, etc.) that you use.
- Keep all chemicals, small parts and anything electrical out of the reach of children.
- Moisture causes damage to electronics. Avoid water exposure to all equipments not specifically designed and protected for this purpose.

CE Compliance Information For The European Union

Carisma hereby declares that this product is in compliance with the essential requirements and other relevant provisions of the RED Directive 2014/53/EU, EN 301 489-1 V2.1.1, EN 301 489-17 V3.1.1, ETSI EN 300 328 V2.1.1

The associated regulatory agencies of the following countries recognize the noted certifications for this product as authorized for sale and use.

UK	DE	DK	BG	SE	CZ	ES	NL	SK	HU	RO	FR	PT
FI	EE	LV	LT	PL	AT	CY	SI	GR	MT	IT	IE	LU

Products: CTX-2000, MRS-24BL
Equipment Class: 2

FCC Information
FCC ID: YDTC-2000
Item Name: CTX-2000 2.4GHz Transmitter

The objects of declaration described above are in conformity with the requirements of the specifications listed below.

Manufactured By: Mun Ah Plastic Electronic Toys Company, Ltd
Statement - This device complies with Part 15 of the FCC Rules.

Operation is subject to the following two conditions:

- (1) this device may not cause harmful interference, and
- (2) this device must accept any interference received, including interference that may cause undesired operation.

Changes or modifications not expressly approved by the party responsible for compliance could void the user's authority to operate the equipment.

RF Exposure Warning:
This equipment complies with FCC radiation exposure limits set forth for an uncontrolled environment.
And should be operated with minimum distance of 20 cm between the antenna & your body.

Instructions for Disposal of WEEE by Users in the European Union

This product must not be disposed of with other waste. Instead, it is the user's responsibility to dispose of their waste equipment by handing it over to a designated collection point for the recycling of waste electrical and electronic equipment. The separate collection and recycling of your waste equipment at the time of disposal will help to conserve natural resources and ensure that it is recycled in a manner that protects human health and the environment. For more information about where you can drop off your waste equipment for recycling, please contact your local city office, your household waste disposal service or where you purchased the product.

NCC Warning Statement

Without permission, any company, firm or user shall not alter the frequency, increase the power, or change the characteristic and functions of the original design of the certified lower power frequency electric machinery.

The application of lower power frequency electric machineries shall not affect the navigation safety nor interfere a legal communication, if an interference is found, the service will be suspended until improvement is made and the interference no longer exists.

FCC Information

This equipment has been tested and found to comply with the limits for a Class B digital device, pursuant to part 15 of the FCC Rules. These limits are designed to provide residential protection against harmful interference in a residential installation. This equipment generates, uses, and can radiate radio frequency energy and, if not installed and used in accordance with the instructions, may cause harmful interference to radio communications. However, there is no guarantee that interference will not occur in a particular installation. If this equipment does cause harmful interference to radio or television reception, which can be determined by turning the equipment on and off, the user is encouraged to correct the interference by one or more of the following measures: Reorient or relocate the receiving antenna. Increase the separation between the equipment and the receiver. Connect the equipment into an outlet on a circuit different from that to which the receiver is connected.

FCC Warning:

The equipment may generate or use radio frequency energy. Changes or modifications to this equipment may cause harmful interference unless the modifications are expressly approved in the instruction manual. Modifications not authorized by the manufacturer may void the user's authority to operate this device. This device complies with part 15 of the FCC Rules. Operation is subject to the following two conditions (1) This device may not cause harmful interference, and (2) this device must accept any interference received, including interference that may cause undesired operation. The device has been evaluated to meet general RF exposure requirement. The device can be used in portable exposure condition without restriction.

STUDY THE INSTRUCTIONS THOROUGHLY BEFORE ASSEMBLY.

There are many small screws, nuts and similar parts. Please refer to the column on the left to know the exact size. To prevent trouble and finish the model with good performance, it is necessary to assemble each step exactly as shown.

ABOUT THE RADIO SYSTEM

CTX-2000 2.4GHz FHSS Technology System

The following is an overview of the various functions and adjustments found on CTX-2000 radio system. It is important to read and understand about all of these functions and adjustments before driving.

FUNCTIONS

TRANSMITTER CTX-2000

Steering Wheel : Control direction (Left/Right) of the RC model.

Throttle Trigger : Control speed and direction (Forward/Brake/Backward) of the driving model.

ON / OFF Switch : Power ON / OFF the transmitter.

SW1 Button : Is used to synchronize the connection between the transmitter and the receiver. It also serves as additional function on different model.

LED Indicator : For indicating battery low, pairing in progress and normal operation.

ATV : Adjust the maximum steering angle on both sides when model turns Left / Right.

ST. Trim Dial : Adjust the neutral position of steering servo when model wheels are straight ahead.

TH. Trim Dial : To adjust the throttle position

Steering Reverse : Reverse the response direction when operating Steering Wheel.

Throttle Reverse : Reverse the response direction when operating Throttle Trigger.

Throttle Limit Switch : Set the max Forward Speed of the model.

* In general, user will experience under steer when making a wide turn at high speed or over steer when making sharp turn at high speed (easy to spin out). User should practice the Throttle and steering approach for different cornering at different speed or road surface.

Battery Installation

1. Supplied with 4 x 1.5V AA Batteries, radio can be operated a few hours.

Installation: Remove the battery compartment cover as shown below.

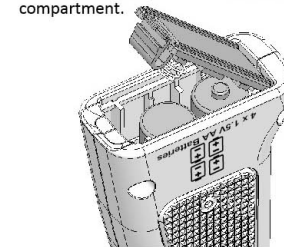

Battery LED Indicator

The LED solid on indicating that the batteries have sufficient power. When batteries voltage drops below 4 volts, LED will Flash, indicating batteries power is low and should be replaced.

Solid ON :
Sufficient Power supply

Flashing ON :
Time to replace batteries

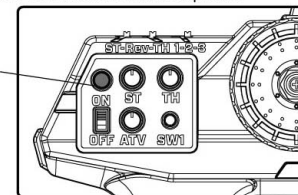

ATV

ATV enables to adjust the maximum steering angle of servo on both sides (Left and Right) when model makes steering. The ATV affects the sensitivity of servo. Reducing dual rate value can lower the sensitivity of servo and reduce the same maximum steering angle on both sides. Remember to adjust the ATV within the adjustment range.

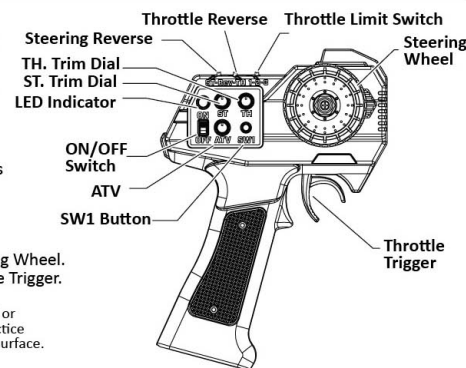
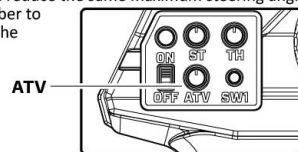

Warning :

Never disassemble batteries or put the batteries in fire, chemical agents, otherwise they may cause personal injuries or property damages.

Battery Disposal :

Observe corresponding regulations about wasted battery treatment regulations.
1. After running out of power, dispose of wasted batteries in designated areas far away from water supply, household areas and planted areas.
2. Submit the wasted batteries to specific recycling stations.

Pre-Run Check

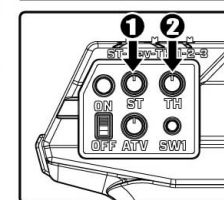

1. Steering : Adjust the steering trim to keep the front wheels in straight line when steering wheel remains in NEUTRAL position.

2. Throttle : Adjust the throttle trim to make the motor stop while throttle trigger at NEUTRAL position.

* Always turn on the transmitter first. If the LED is not solid on, you need to check whether the batteries are good or incorrectly installed.

Reversing

Steering Reverse: Reverse the response direction when operating steering wheel. Turning left steering wheel, the model turns right while turning right the model turns left.

Throttle Reverse: Reverse the response direction when operating throttle trigger. Pushing forward throttle trigger the model moves backward while pulling back, the model moves forward. If necessary you can just use a small screwdriver to adjust the responding switches.

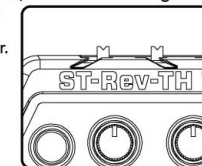

Throttle Limit Switch

The slide switch to select the max forward speed:

- 1: Slowest
- 2: Intermediate
- 3: Fastest

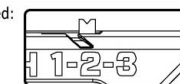

RECEIVER CONNECTION AND INSTALLATION

Carisma MRS-24BL RX/ESC Unit Synchronization

To Sync the Radio to the Car

STEP 1: Locate the SYNC button on the main chassis by removing the body (the Round button)

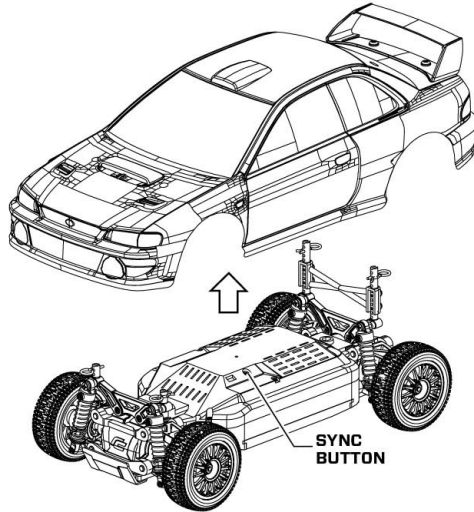

STEP 2: Keep the Radio Power to **OFF** Position

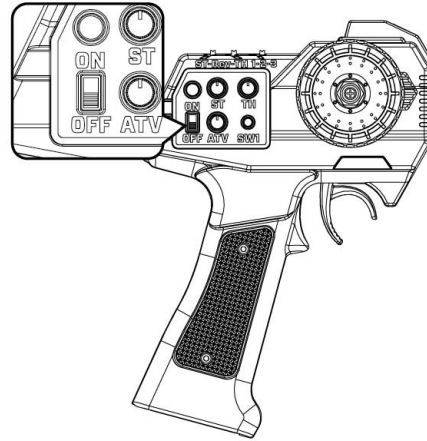

STEP 3: Press and HOLD the Chassis SYNC Round Button while Power ON

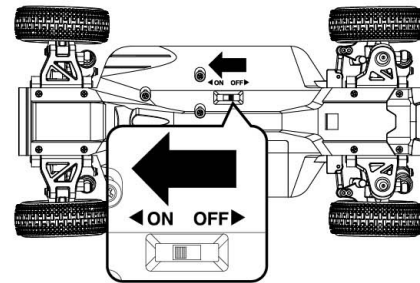
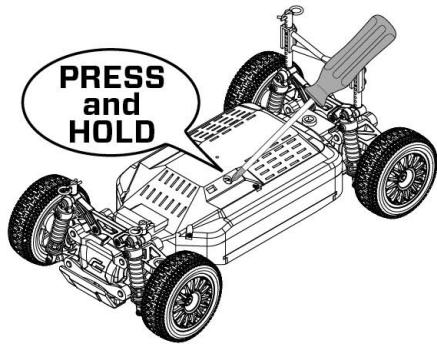

STEP 4: The LED will flash, release the SYNC button

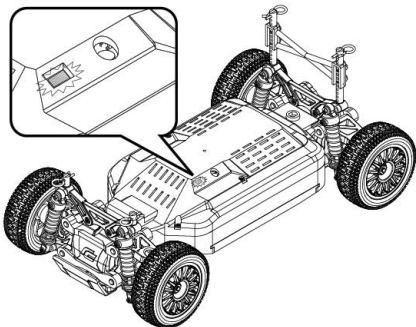

STEP 5: PRESS and HOLD the SW1 button on the transmitter and Power ON.

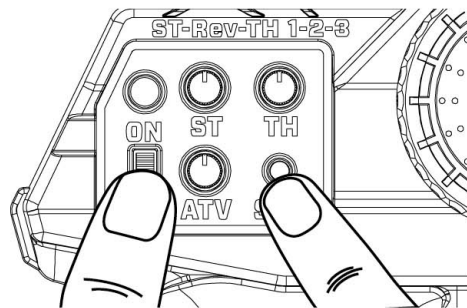

RECEIVER CONNECTION AND INSTALLATION

STEP 6: Car LED should be ON SOLIDLY and its now READY to play.
If fail to connect, Repeat from step 1 again.

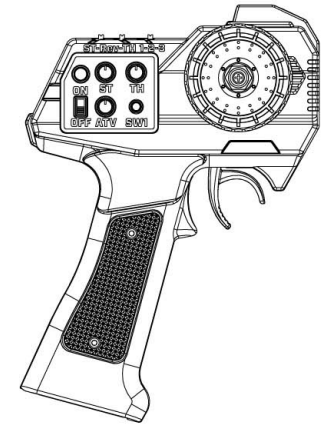
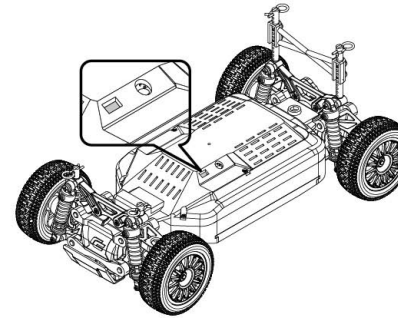

MRS-24BL RX/ESC UNIT SETUP

ESC SETUP

Just use the TH. Trim to locate the Neutral Position. Nothing else to set.
The ESC is a Forward and Brake/Reverse function.

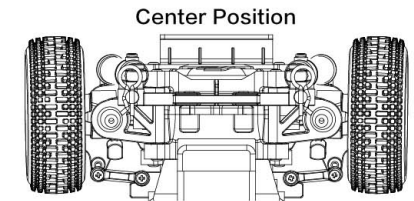
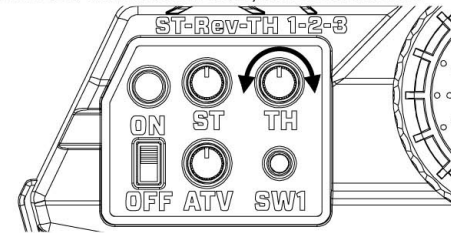

WARNING:
Maximum is 2S LiPo (7.4V) DO NOT EXCEED this voltage, otherwise will damage and void warranty.

CARISMA MRS-24BL RX/ESC UNIT FEATURES

1. LED indicator

The LED serve two function:

- Indicate present of TX
- Indicate the Battery Type selected
 - Solid ON = NIMH
 - Flashing = LiPo

2. Setting Battery Type

- TX power on and at stop position
- Power RX, wait for few second, and then press and hold the RX button until LED changed, new battery type is updated.

3. Power Off reminder

After loss of TX signal over 5 sec, will use LED and servo to warn the user to POWER OFF the car, to avoid over discharge and damaging the battery.

- LED quickly flashed 2 times per 2 sec
- Servo will be moved once shortly per 10 sec.

